

# SURVEY OF LOT NO. 8710

MASSILLON, STARK, OHIO

FOR Sibila

DATE 2-23-52

BY H. M. PIPER — REGISTERED ENGINEER AND SURVEYOR

SCALE: 1" = 40 FT.

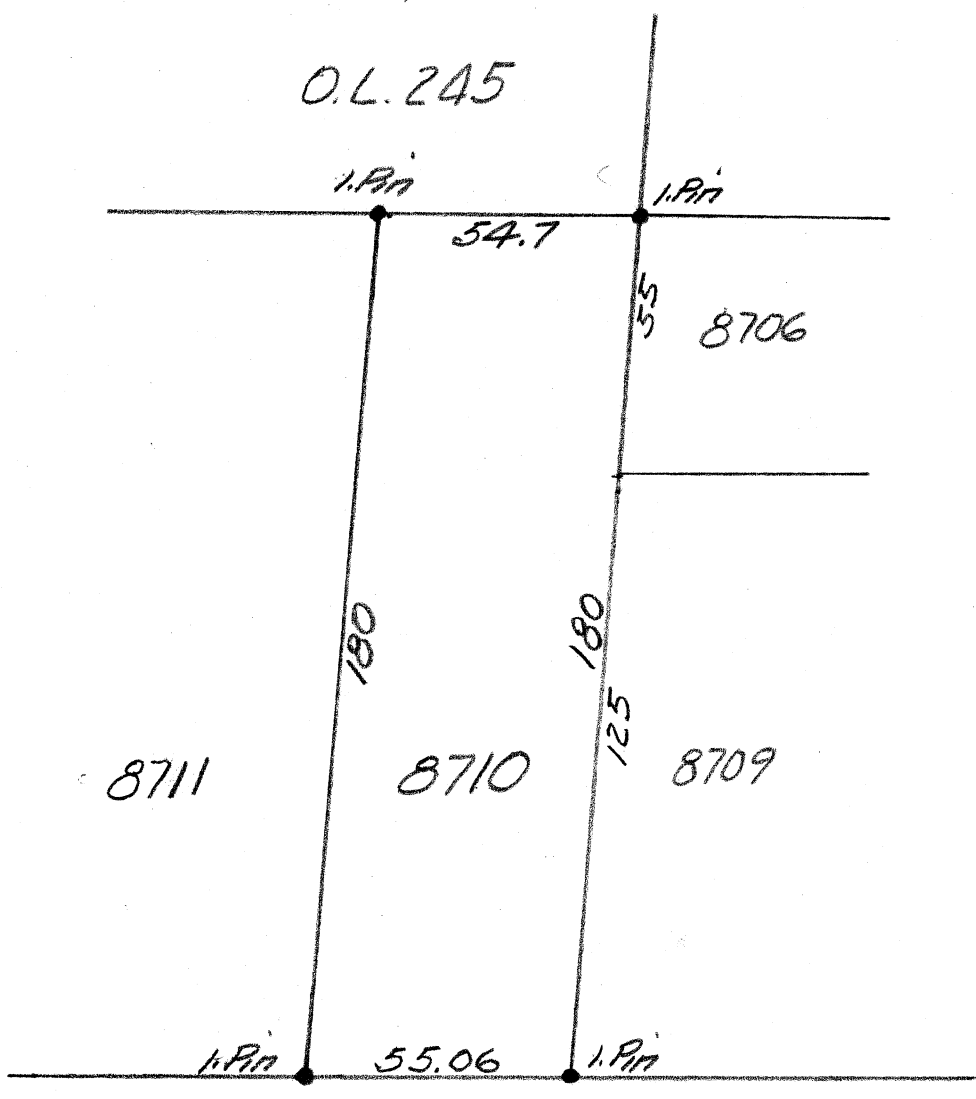

SCHULLER AVE. NW. 50'

3

✓ 313

SURVEY OF PT. LOT NO. 8711

MASSILLON, STARK, OHIO

FOR John Sibila

DATE 4-9-55

BY H. M. PIPER - REGISTERED ENGINEER AND SURVEYOR

SCALE: 1" = 40'

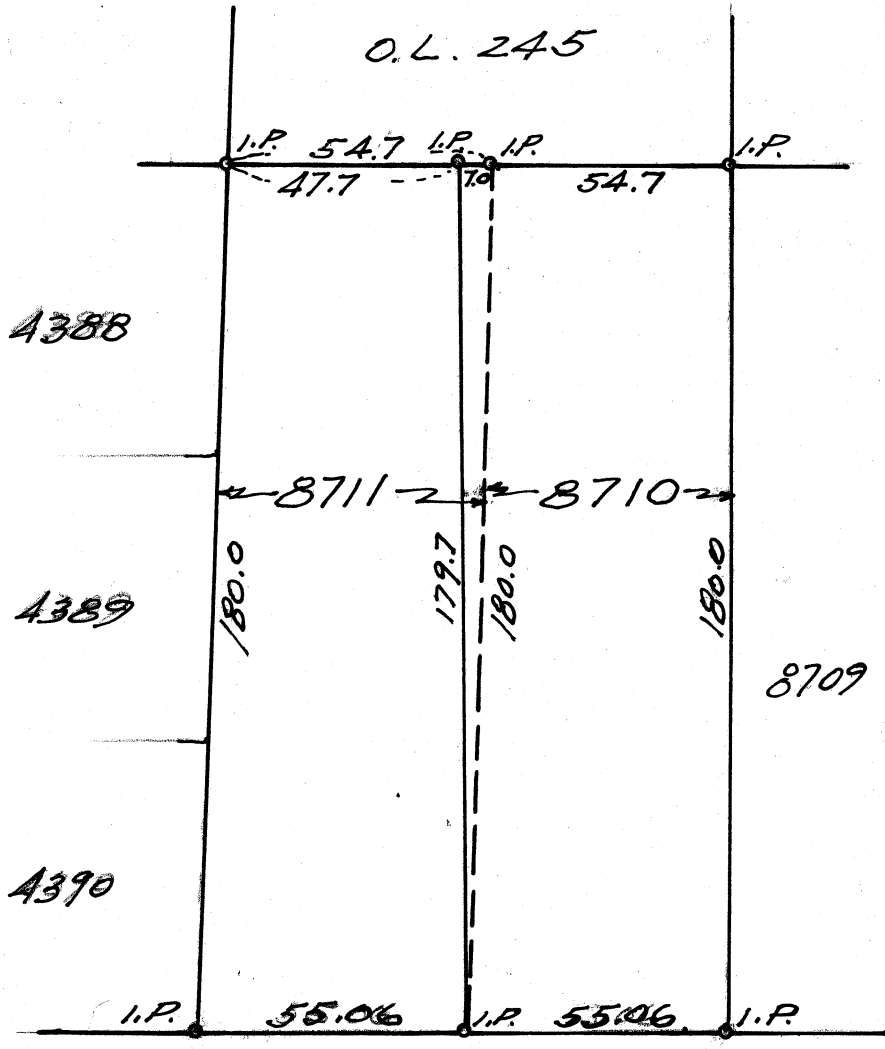

SCHULLER AVE. N.W. 50'

DESCRIPTION FOR PART OF LOT NO. 8711

For John Sibila - 2620 Schuller Ave. N. W.

Known as and being a Part of Lot No. 8711 in the City of Massillon, Ohio, according to the present numbering of Lots in said City and being more fully described as follows:

Beginning at an iron pin on the north line of Lot No. 8711 47.70 feet east of the Northwest corner of said lot, said point being the true place of beginning of the parcel here-in described; thence easterly along said north line 7.0 feet to the northeast corner of Lot No. 8711; thence southerly 180.0 feet to the southeast corner of said Lot; thence northerly 179.7 feet to the place of beginning containing 630 square feet.